

PLASTIC PARTS

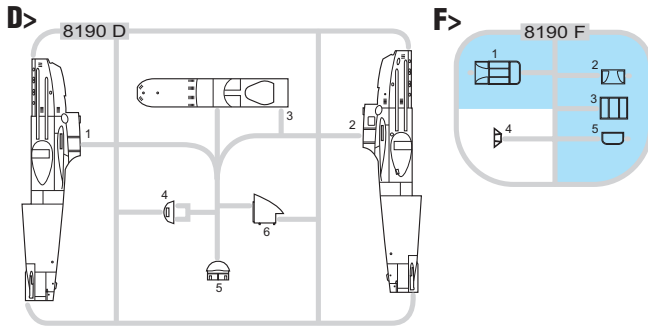
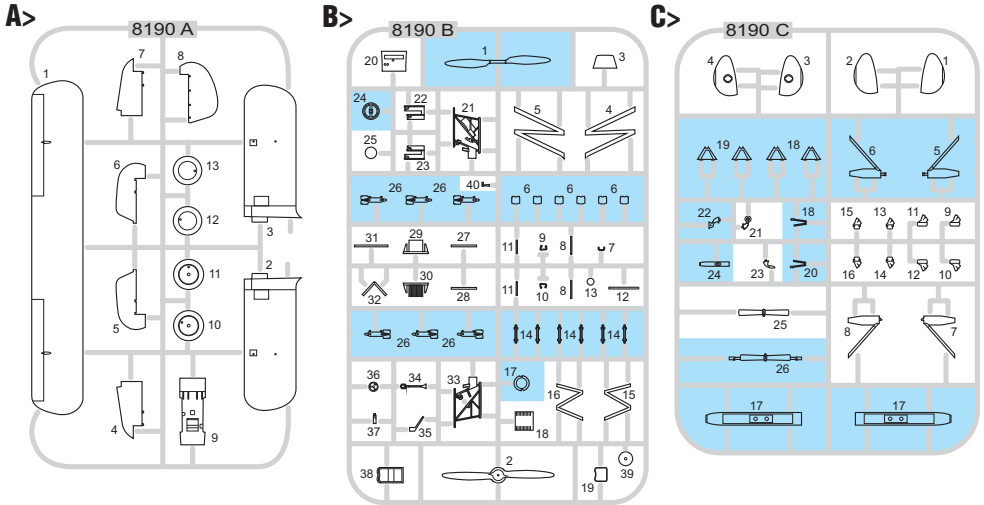

GUNZE		
H8	C8	SILVER
H11	C62	WHITE
H12	C33	FLAT BLACK
H28	C78	METAL BLACK
H37	C43	WOOD BROWN
H47	C41	RED BROWN
H77	C137	TIRE BLACK
H80	C54	KHAKI GREEN
H413	C113	YELLOW RLM04
Mr. METAL COLOR		
MC214	DARK IRON	
MC215	COPPER	

-Parts not for use. -Teile werden nicht verwendet. -Pièces à ne pas utiliser. -Tyto díly nepoužívejte při stavbě. - 使用しない部品

ATTENTION * UPOZORNĚNÍ * ACHTUNG * ATTENTION

- (GB)** Carefully read instruction sheet before assembling. When you use glue or paint, do not use near open flame and use in well ventilated room. Keep out of reach of small children. Children must not be allowed to suck any part, or pull vinyl bag over the head.
- (CZ)** Před započatím stavby si pečlivě prostudujte stavební návod. Při používání barev a lepidel pracujte v dobře větrané místnosti. Lepidla ani barvy nepoužívejte v blízkosti otevřeného ohně. Model není určen malým dětem, mohlo by dojít k požití drobných dílů.
- (D)** Vor dem Zusammenbau die Bauanleitung gut durchlesen. Kleber und Farben nicht in der Nähe von offenem Feuer verwenden und für eine ausreichende Belüftung sorgen. Den Bausatz von kleinen Kindern fernhalten. Vermeiden Sie, dass Kinder Bauteile in den Mund nehmen oder sich Plastiktüten über den Kopf ziehen.
- (F)** lire soigneusement la fiche d'instructions avant d'assembler. Ne pas utiliser de colle ou de peinture à proximité d'une flamme nue, et aérer la pièce de temps en temps. Garder hors de portée des enfants en bas âge. Ne pas laisser les enfants mettre en bouche ou sucer les pièces, ou passer un sachet vinyl sur la tête.

INSTRUCTION SIGNS * INSTR. SYMBOLY * INSTRUKTION SINNBILDEN * SYMBOLES

- OPTIONAL VOLBA
- BEND OHNOUT
- OPEN HOLE VYVRTAT OTVOR
- SYMETRICAL ASSEMBLY SYMETRICKÁ MONTÁŽ
- REMOVE ODŘÍZNOUT
- REVERSE SIDE OTOČIT

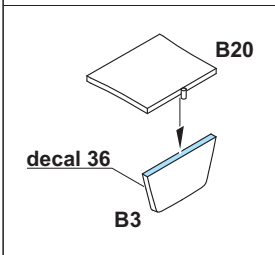
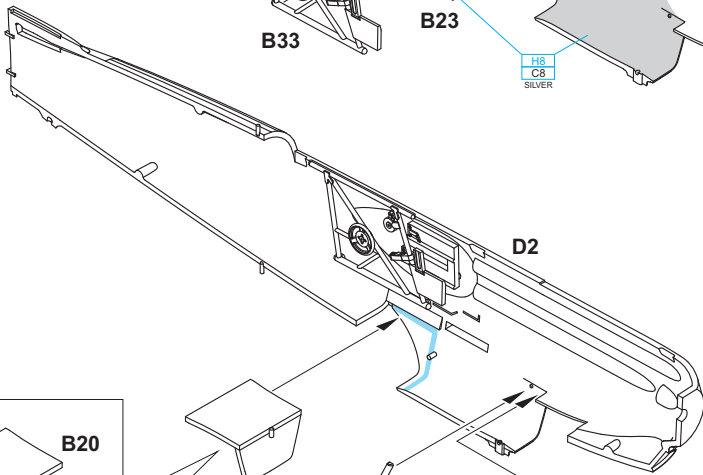
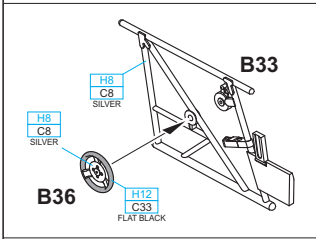
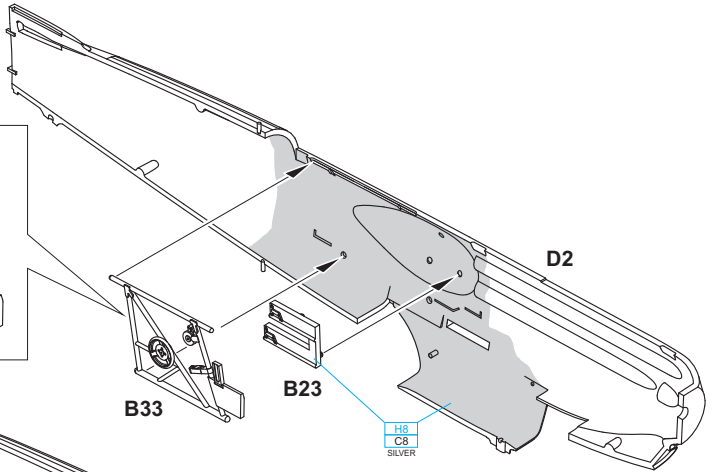
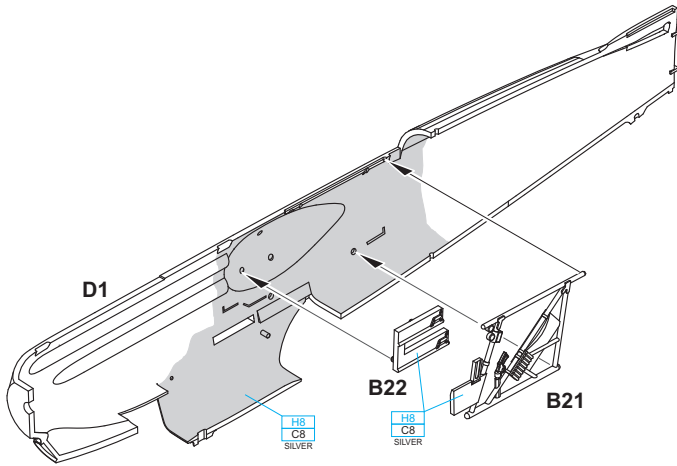

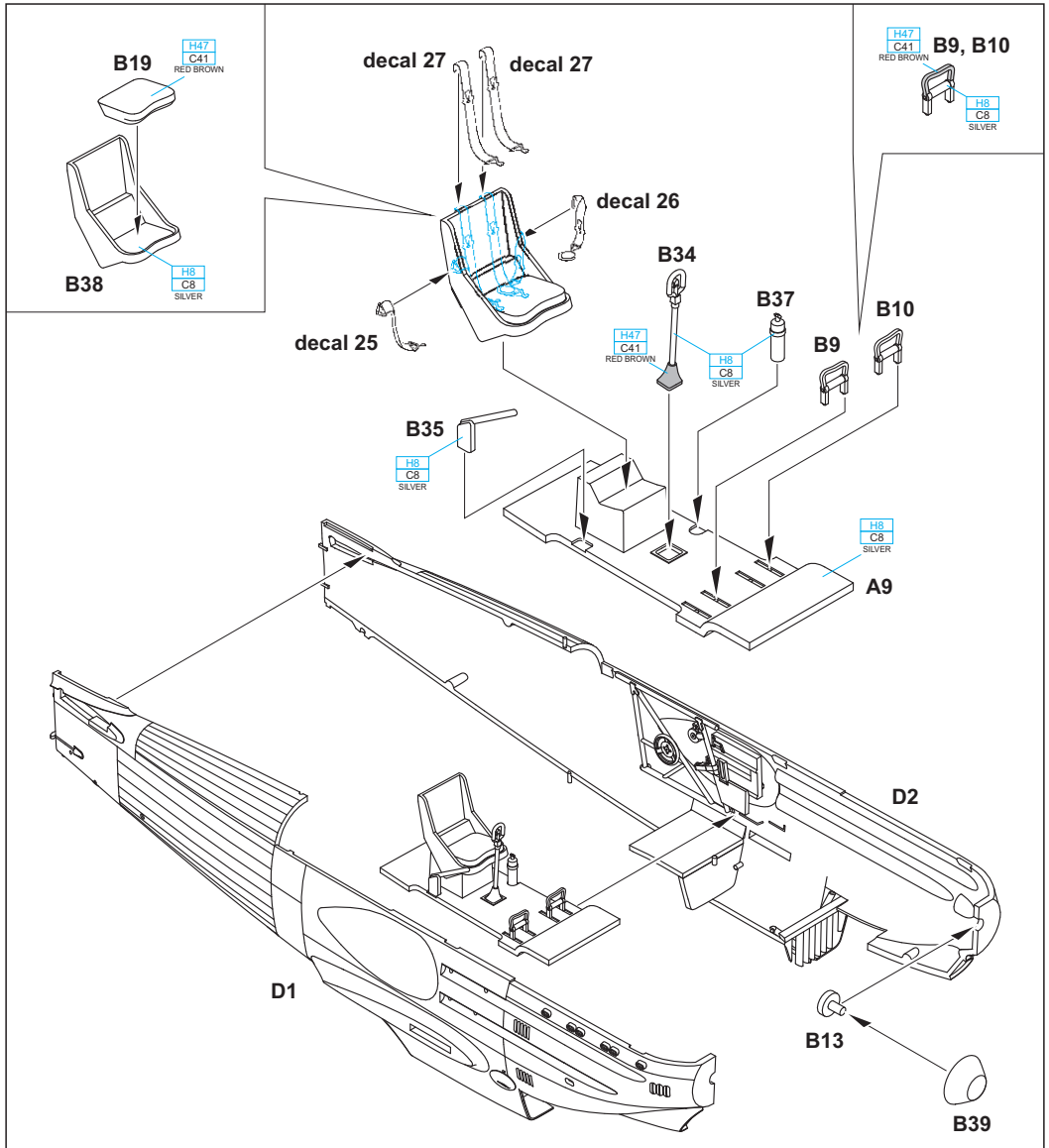

**OPTIONAL
decal 32**

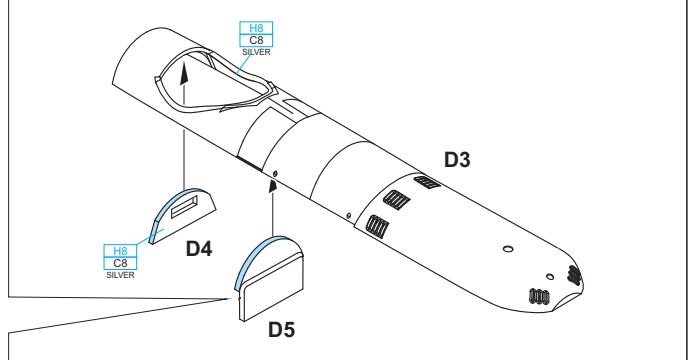
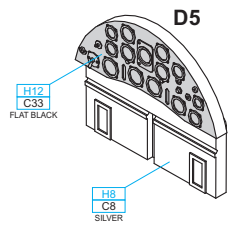

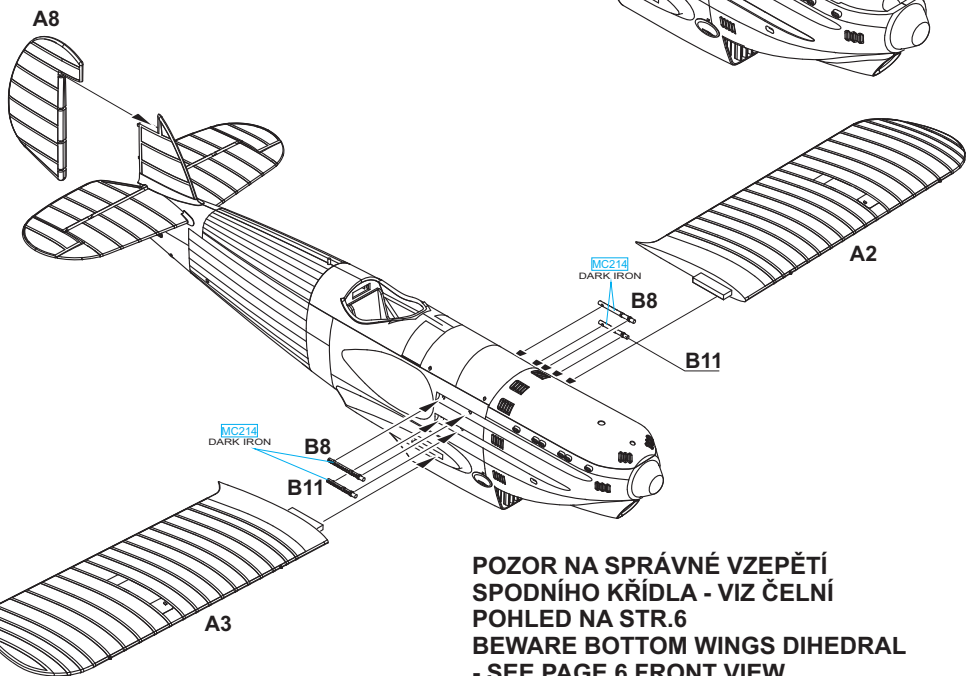
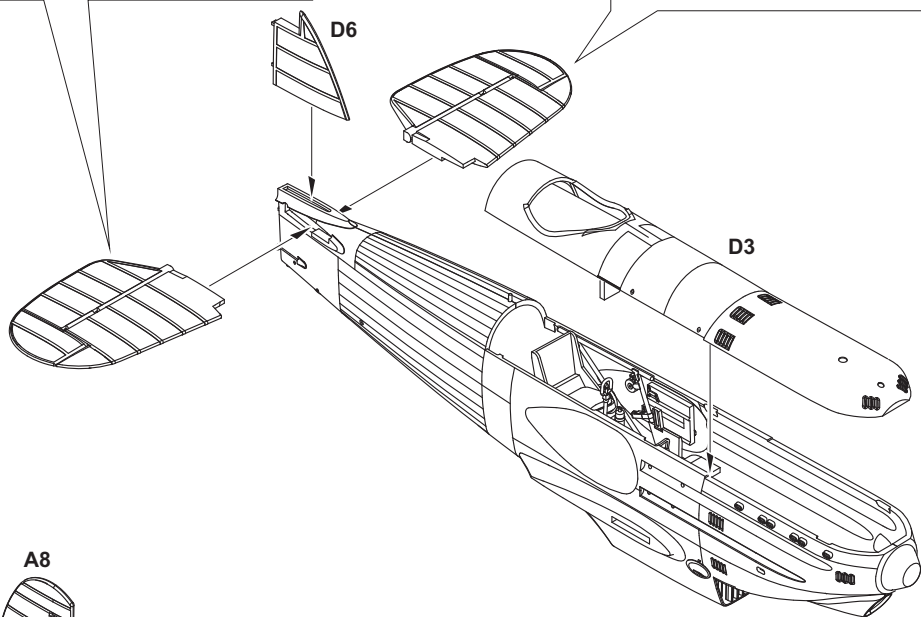
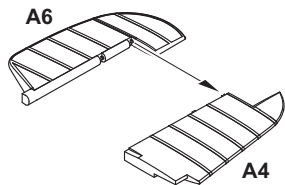
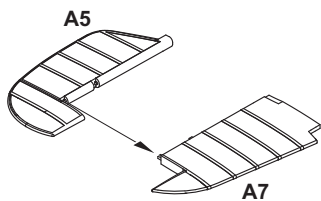

**POZOR NA SPRÁVNÉ VZEPĚTÍ
 SPODNÍHO KŘÍDLA - VIZ ČELNÍ
 POHLED NA STR.6
 BEWARE BOTTOM WINGS DIHEDRAL
 - SEE PAGE 6 FRONT VIEW**

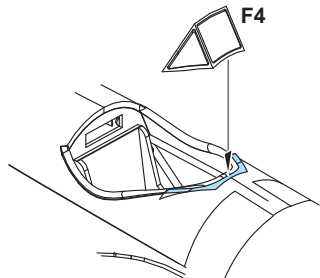
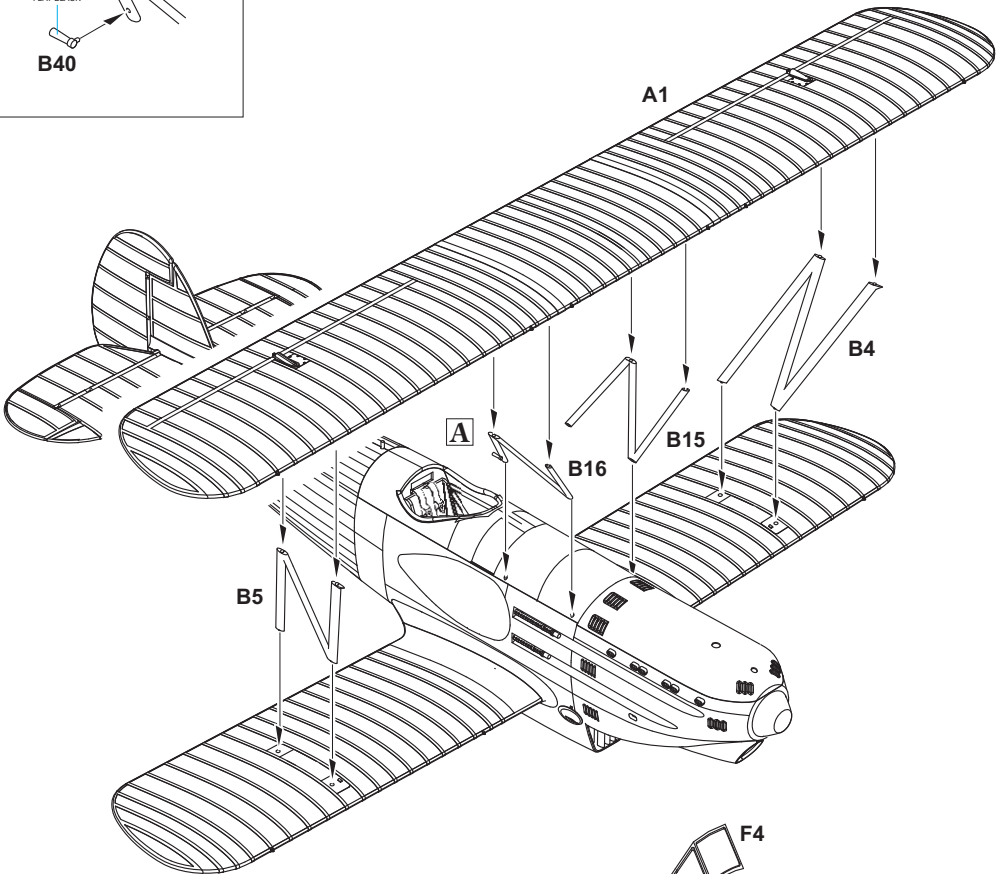
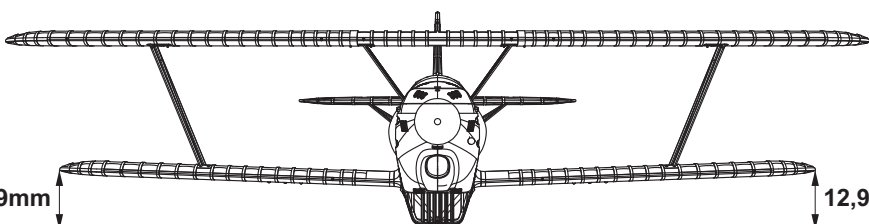
A**B16**H12
C33
FLAT BLACK**B40****POZOR NA SPRÁVNOU ORIENTACI A POZICI
VZPĚR!
BEWARE CORRECT STRUTS POSITION!****F4**

12,9mm

12,9mm

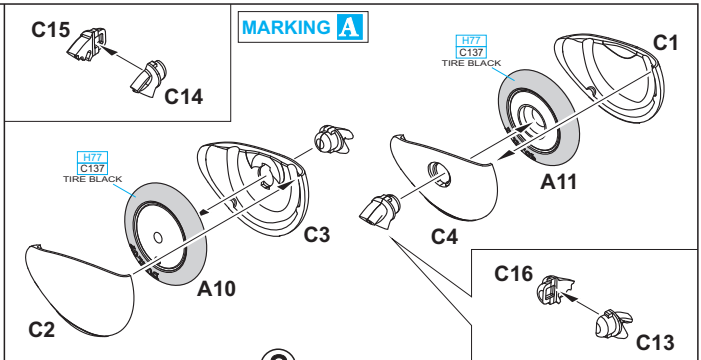
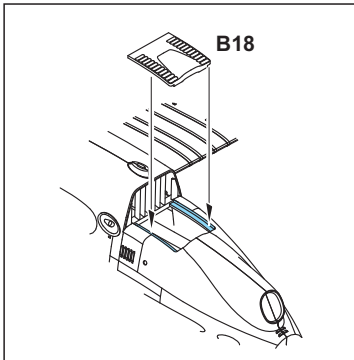

C21 - MARKING B **C23 - MARKING A**

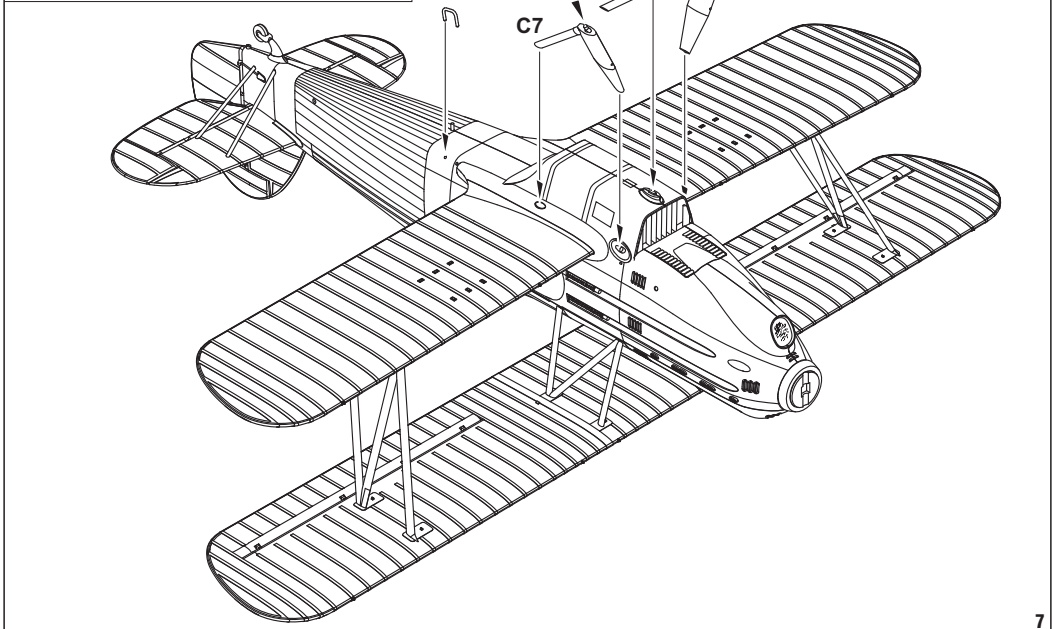
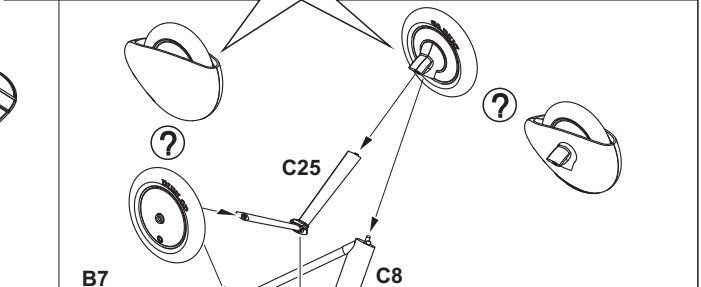
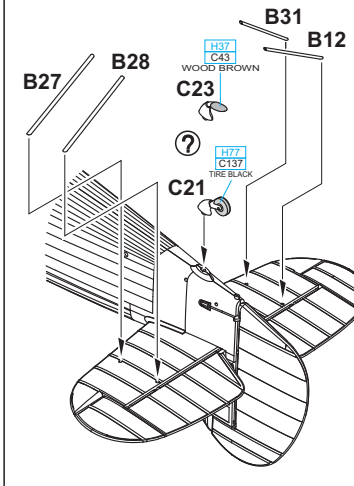
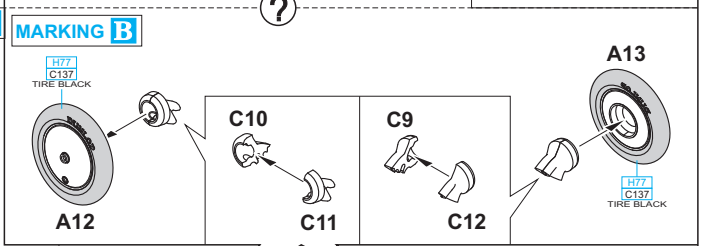

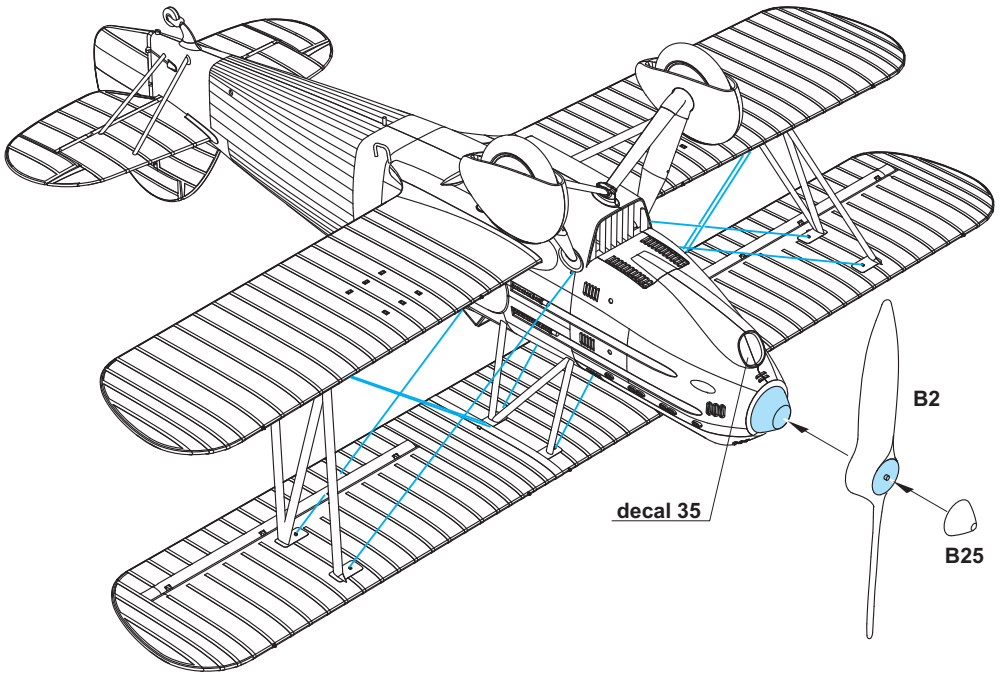

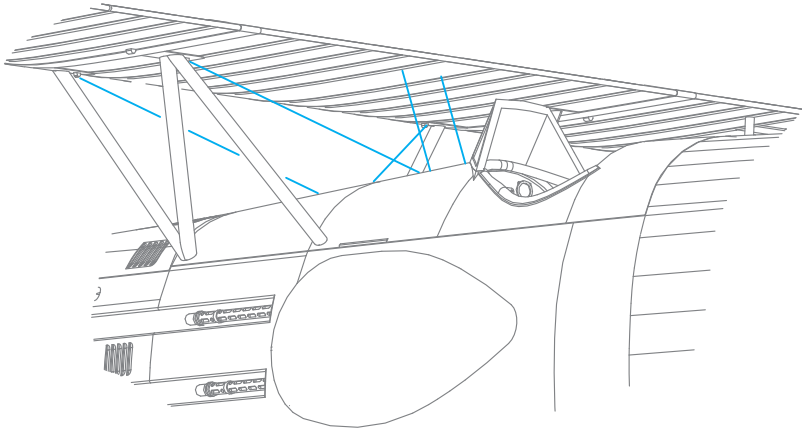

MARKING **A** ONLY

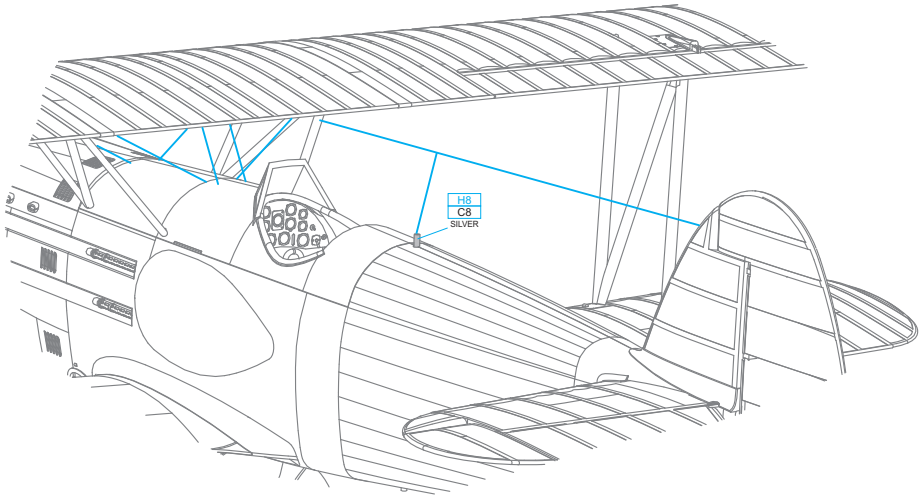

LOWER SURFACE OF TOP WING

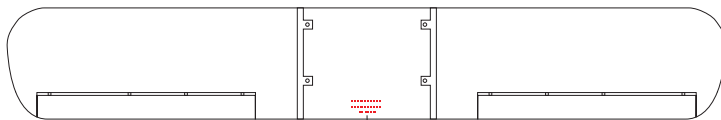

BENZIN. NÁDRŽ HLAV. 257 L
 BENZIN. NÁDRŽ SPÁD. 90 L
 OLEJ. NÁDRŽ 38 L

38

10 PLNĚNÍ VODY

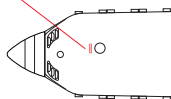

13 ZDE ZVEDATI

11 ZDE DRŽETI PŘI MOTOROVÉ ZKOUŠCE

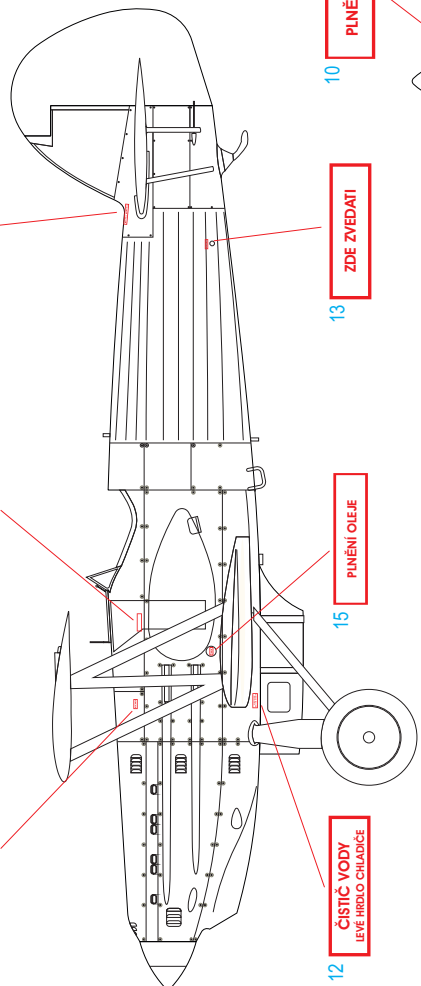

17 PLNĚNÍ HASIČIHO PŘÍSTROJE

15 PLNĚNÍ OLEJE

14 PLNĚNÍ PALIVA

12 ČISTIČ VODY
 LEVÉ HRDLO CHLAZIČE

11 ZDE DRŽETI PŘI MOTOROVÉ ZKOUŠCE

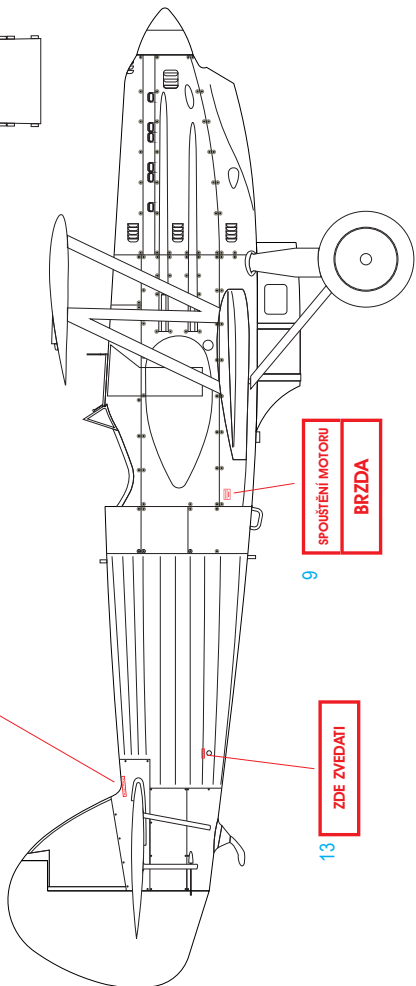

9 SPOUŠTĚNÍ MOTORU
 BRZDA

13 ZDE ZVEDATI